

# EcoPower4™

POWER CONDITIONING FOR YOUR HOME

## OWNER'S MANUAL

read these instructions before use • save this manual

### MODEL ECP240R

NEMA 3R OUTDOOR ENCLOSURE and FLUSHMOUNT

- Installation
- Operation
- Specifications
- Warranty



300 East Valley Drive  
Bristol, VA 24201  
1.800.989.2299

© 2009. DBG Group Investments, LLC

300 East Valley Drive, Bristol, VA 24201, dba EcoTrust Energy. All Rights Reserved

**WARNING:**

1. Opening the unit without prior permission from EcoTrust Energy will void its warranty coverage. Contact EcoTrust Energy at 1.800.989.2299 if you have any questions.
2. Apply this unit to 240V AC, 50/60Hz, single phase residential load only.
3. The unit must be mounted vertically, in a dry location, using the four mounting holes.
4. The unit must be installed by a licensed electrician in compliance with local electrical code.
5. **IMPORTANT!** This unit must be connected directly to a dedicated circuit breaker. Do not, under any circumstances, hard-wire install without a dedicated breaker!

**YOU WILL NEED:**

1. A dedicated, 2-pole, 20 Amp, circuit breaker.
2. Appropriate tools including conduit.
3. A licensed electrician for installation.

**MOUNTING THE ECOPOWER4™ FLUSHMOUNT (ECP240R)**

1. Inspect the exterior of the unit to ensure that it has not been damaged in transit. Ensure that the front label/overlay is still intact, that the warranty seals are intact, and that the cables protruding from the unit have not been damaged.
2. Place the back of the Flushmount Box against wall where the unit is to be installed and trace around its outside edge. Cut drywall along traced line (dimension of traced area should be approximately 4.866" wide by 8.250" high).
3. Run conduit (according to code) between the conduit connector on the box and the power panel, and feed the connection cables through the conduit into the power panel.
4. Secure the four (4) clips to the mounting box and tighten screws to tightly fit.
5. Screw Cover Plate onto unit.

**MOUNTING THE ECOPOWER4™ NEMA 3R (ECP240R)**

1. Inspect the exterior of the unit to ensure that it has not been damaged in transit. Ensure that the front label/overlay is still intact, that the warranty seals are intact, and that the cables protruding from the unit have not been damaged.
2. Mount the unit to a clean, dry wall near the power panel. Lengthening of the wires to accommodate mounting the unit further away from the panel than the current wiring allows may be necessary. As a general rule, the length of the wires should be kept as short as possible and electricians should follow standard electrical code regarding adding wire to the unit. When mounted, the phase indication lights should be visible.

- Run conduit (according to code) between the conduit connector on the box and the power panel, and feed the connection cables through the conduit into the power panel.

### INSTALLATION PROCEDURES:

- If possible, de-energize the power panel prior to connection of the EcoPower4™ unit.
- Install the circuit breaker onto the power panel.
- US/Canadian Installation - Connect the (red) L1 and (black) L2 wires to the circuit breaker, the ground cable (green) to the ground bus, and the neutral cable (white) to the neutral bus, as shown in the diagram below.
- International Installation (240V, 50Hz) - Connect the brown wire (hot) to the circuit breaker, the ground wire (green with yellow stripe) to the ground bus, and the blue wire to the neutral bus as shown in the diagram below.

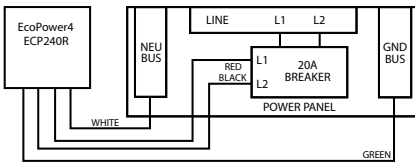

US/CANADIAN INSTALLATION

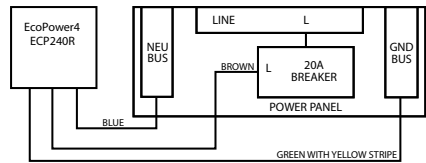

INTERNATIONAL INSTALLATION

### TEST PROCEDURES:

- Energize the power panel.
- Close the circuit breaker leading to the EcoPower4™ unit.
- Check if Line 1 and Line 2 indicator lights are on:  
IF NO - De-energize the unit and check if cables are connected correctly.  
NOTE: For international appliances, only 1 indicator light may be on.  
Check the ground cable connections.  
If problem persists, call EcoTrust Energy at 1.800.989.2299.
- Keep these instructions near the unit for future use.

### RATINGS:

#### Voltage:

US/CA: 120/240V~, 2W + N + PE,  
60Hz, 2.7A

International: 240V~, 50Hz, 2.7A

#### Configuration:

3-wire plus ground (US)

2-wire plus ground (International)

**Capacitance:** 30µf (US)

**Line Current:** 2.7 A

**KVA Rating:** .65 at 240V AC

**DIMENSIONS FOR THE ECOPOWER4™ FLUSHMOUNT (ECP240R)**

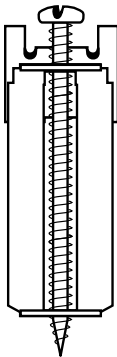
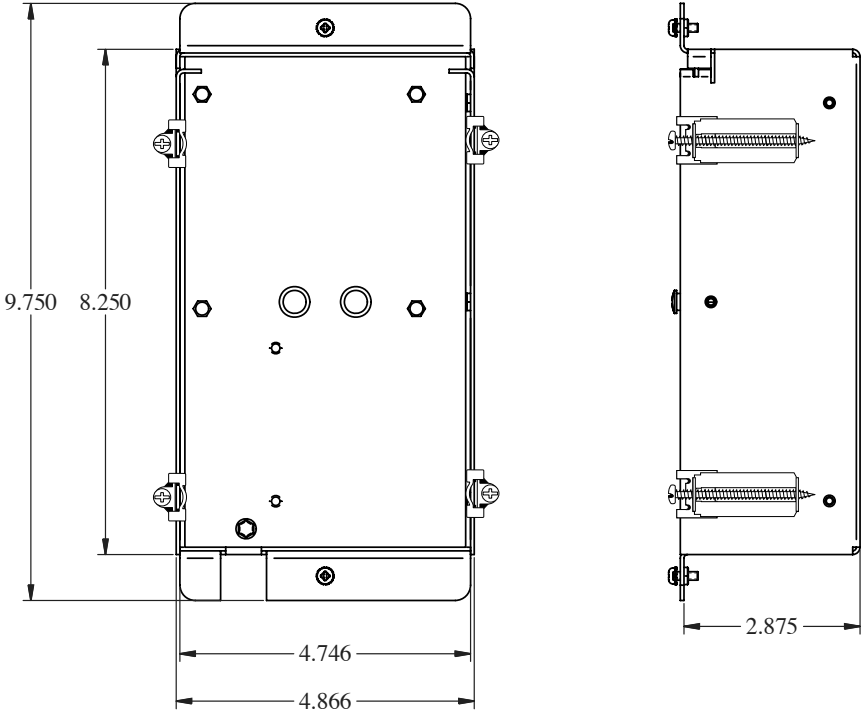

MOUNTING CLIPS (4X)  
FOR FLUSHMOUNT

**DIMENSIONS FOR THE ECOPOWER4™ NEMA3 (ECP240R)**

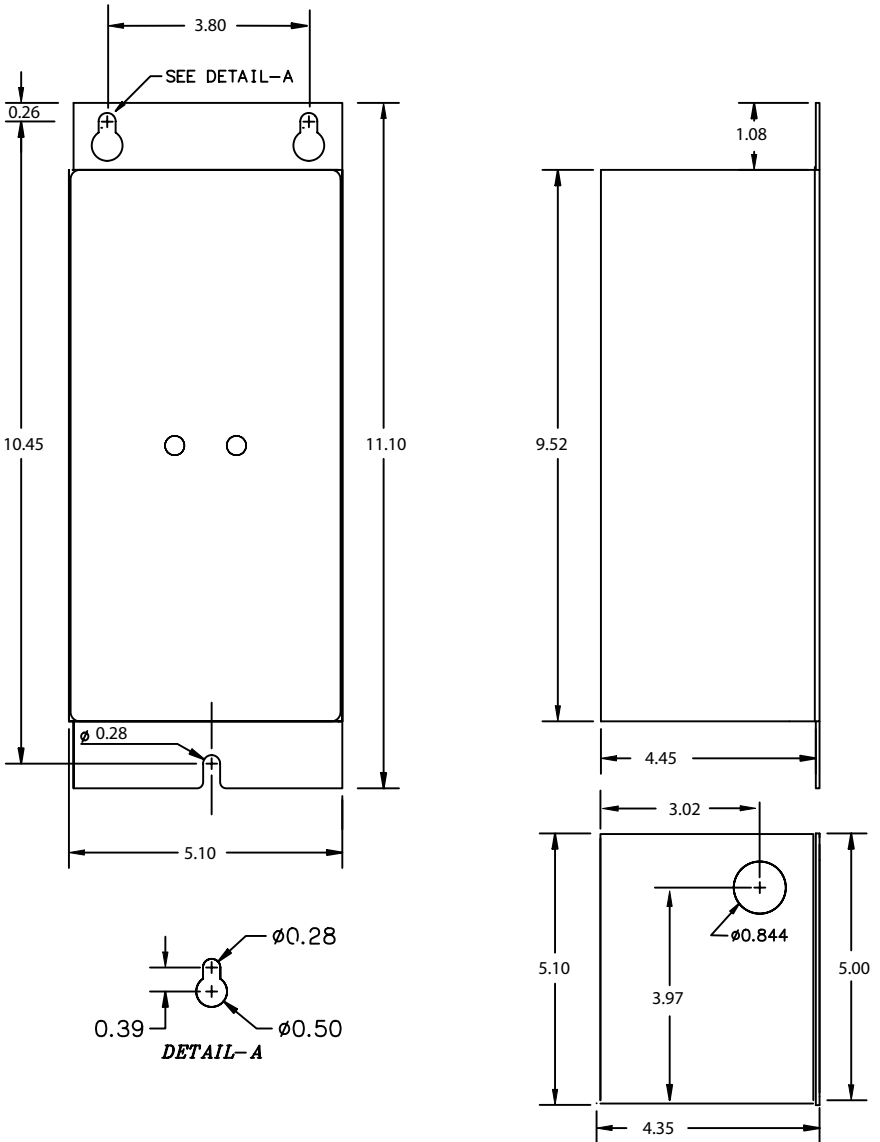

# CE DECLARATION OF CONFORMITY

We, on behalf of the manufacturer:

DBG Group Investments, LLC  
300 East Valley Drive  
Bristol, VA 24201  
U.S.A.

Declare under our sole responsibility, that the Energy Management Device

Model: EcoTrust Energy ECP240R (NEMA 3R and Flushmount)

to which this declaration relates, conforms with the following standards:

EN60950-1:2006 Safety of Information Technology Equipment - General Requirements

By conformance with the standards referenced, the product meets the provisions of the EU Directives listed below:

Low Voltage Directive	73/23/EEC as amended by 98/68/EEC
RoHS Directive	2002/95/EC
WEEE Directive	2002/96/EC

Authorized by:



Representative:  
Title:  
Company:

Robert S. Vincent  
General Manager  
Quest United UK Ltd.  
The Atrium  
Curtis Road  
Dorking, Surrey RH4 1XA  
United Kingdom

Date:

April 24, 2009



300 East Valley Drive  
Bristol, VA 24201  
1.800.989.2299

